



# AFC系列电脑横机

## AFC SERIES COMPUTERIZED FLAT KNITTING MACHINE

AFC252/AFC352/AFC380 高效5.2英寸小机头  
Efficient 5.2-inch small carriage

本机型技术亮点：1, 弧形天杠导轨；2, 智能自跑纱嘴，可控纱嘴上下动作  
The technical highlights of this model :

1. Equipped with 4 pcs arc-shaped feeder rail
2. Equipped with Fully auto controlled feeder system





# AFC352/AFC380

4根自跑式纱嘴弧形导轨，16个自跑式纱嘴，电脑控制纱嘴上下运动位置。可精准实现嵌花、正反盖毛，减少纱嘴回踢，提高编织效率，是电脑横机的最新专利创新技术。

Equipped with 4 pcs arc-shaped feeder rail, 16 pcs auto motor-driven feeders, the movement of which are controlled by computer up or down. This could precisely realize the knitting of intarsia, inverse plying, and reduce running course, to improve knitting efficiency. It is the latest innovation proprietary technology.



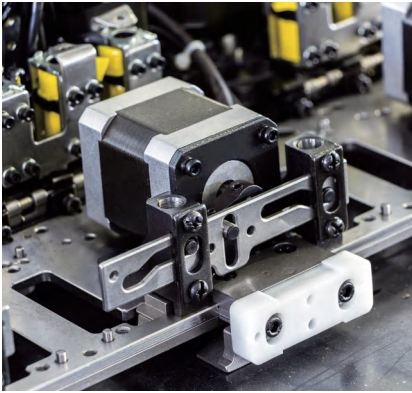

电机推针结构，缩短编织行程，回转稳  
 The cam system utilizes motor-controlled needle raising structure, carriage effective movement distance is shortened, carriage return become faster and more stable.



正反盖毛组织颜色鲜明，织片平整。  
 The front and back capping structure are more colorful and smoother.



上下运动沙嘴，可做嵌花，正反盖毛。  
 Up-and-down motion of feeder is more useful and effective for making intarsia and capping structure.



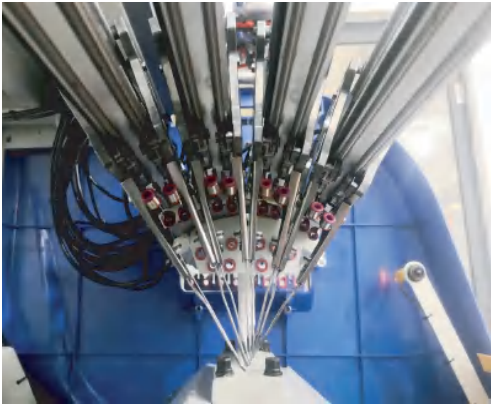

4根弧形导轨16把自跑沙嘴，减少回踢，提高编织效率，可做到最多16个颜色嵌花。

4 pcs arc-shaped feeder rail, 16 pcs auto motor-driven feeders, are utilized to reduce free carriage movement.

Knitting efficiency are improved, 16 colors intarsia structure can be made maximumly.

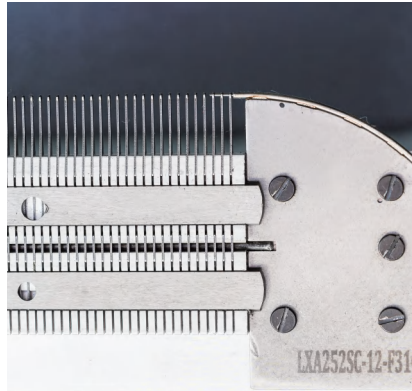

可选配零间纱起底板，无需废纱起底，大大提高生产效率，节约人工成本。

Non-waste yarn starting comb is selectable for saving yarn and labor cost.

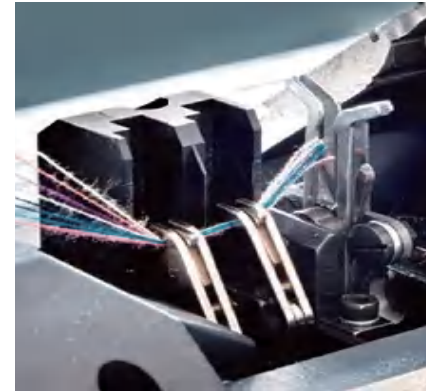

可靠的剪刀夹子装置，通过系统控制，实现自动夹纱剪纱操作。

Stable scissor and gripper are controlled by program, auto grip and cut motion are realized.



## 产品参数

Model 机器型号	AFC252	AFC352	AFC380
Basic parameters 基础参数	● Standard configuration    ○ Optional    — Without		
Gauge 针型	5G/7G(V)/8G/9G/10G/12G(V)/14G(V)/16G/18G/20G		
Carriage 机头数量	1	1	1
Knitting system 编织系统	2 SYSTEM	3 SYSTEM	3 SYSTEM
Width (INCH) 宽度 (英寸)	52	52	80
Inset needle bed 插片针板	●	●	●
Running speed (M/S) 运转速度 (米/秒)	1.4	1.4	1.4
SMALL Carriage 小机头	●	●	●
Probe 探针	Infrared	Infrared	Infrared
Motor transfer 马达翻针	○	○	○
Machine two side tool box 两边工具箱	●	●	●
Cleaning system 清洁系统	—	—	—
Motor driving selection JACK raise cam 马达换向	○	○	○
Needle bed racking 针板摇床	±2inch	±2inch	±2inch
Sinker 信克	●	●	●
Lubrication system (auto, manual, none) 润滑系统 (自动、手动、无)	Auto	Auto	Auto
Tight tuck 紧吊目	—	—	—
Dynamic density 可变量目	●	●	●

Model 机器型号	AFC252	AFC352	AFC380
Take down device 牵拉系统	● Standard configuration    ○ Optional    — Without		
Rubber roller 皮罗拉	●	●	●
Auto down roller 自动开合下罗拉	○	○	○
Manual down roller 手动开合下罗拉	—	—	—
Comb 起底板	●	●	●
Wire comb 无废纱起底	○	○	○
Scissors 剪刀夹子	● Two side	● Two side	● Two side
Yarn device 喂纱装置	● Standard configuration    ○ Optional    — Without		
Top tension 天线台数量	16PCS /20PCS (V)	16PCS /20PCS (V)	24 PCS
Lycra feeder 氨纶送纱器	—	—	—
Yarn storage device 储纱器	16G/18G/20G		
Yarn supplier device 送纱器	5G/7G (V)/8G/9G/10G/12G (V)/14G (V)		
Yarn carrier 纱嘴	● Standard configuration    ○ Optional    — Without		
Carrier quantity 纱嘴数量	16 PCS	16 PCS	16 PCS
Auto motor-driven carrier 智跑纱嘴	● 16 PCS	● 16 PCS	● 16 PCS
Up-and-down motion carrier 自动上下纱嘴	● 16 PCS	● 16 PCS	● 16 PCS
Weft insetion carrier 衬纬纱嘴	—	—	—
Ultra-wide adjustable carrier (34-47mm) 超宽可调节纱嘴 (34-47毫米)	—	—	—
Double holes 双孔纱嘴	—	—	—

Model 机器型号	AFC252	AFC352	AFC380
Safty device 安全装置	● Standard configuration    ○ Optional    — Without		
Emergency stop devices 紧急停车装置	●	●	●
Safty cover with infrared ray 护罩红外感应	●	●	●
Power cut off device 断电记忆	●	●	●
Alarm device 报警装置	● Standard configuration    ○ Optional    — Without		
Fabric rewind alarm (infrared ray) 布片倒卷报警 (红外线)	—	—	—
Fabric rewind alarm (detection board) 布片倒卷报警 (倒卷板)	●	●	●
Needle crash alarm 撞针报警	●	●	●
Yarn breakage alarm 断纱报警	●	●	●
Yarn knot alarm 纱结报警	●	●	●
Stroke protection device (racking) 摇床限位报警	●	●	●
Stroke protection device (carriage) 机头限位报警	●	●	●
Over load alarm 过载报警	●	●	●
Knit piece finish alarm 编织件数完成报警	●	●	●
Sepecific row stop 指定行停车	●	●	●
Program error 程序错误	●	●	●
Power 电源	● Standard configuration    ○ Optional    — Without		
AC 220V ± 5%(1phase 50/60Hz) 单相220V、50/60HZ	●	●	●
AC 380V ± 5%(3phase 50/60Hz) 三相380V、50/60HZ	○	○	○
Power consumption 功率	1.5 KW	2.0 KW	2.0 KW

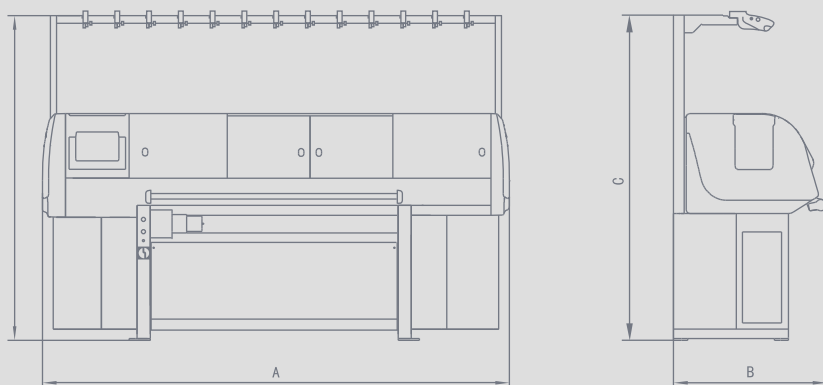

机器型号 MACHINE MODEL	外形尺寸(毫米) BOUNDARY DIMENSTON(mm)	包装尺寸(毫米) PACKAGE DIMENSTON(mm)	净重(kg) NET WEIGHT(KG)	毛重(kg) GROSS WEIGHT(KG)
	长 × 宽 × 高(A×B×C) LENGTH×WIDTH×HEIGHT(A×B×C)	长 × 宽 × 高 LENGTH×WIDTH×HEIGHT		
AFC252	2730×900×1900	2900×1050×1820	950	1130
AFC352	3000×875×1850	3100×1050×1820	1050	1250
AFC380	3750×875×1850	3850×1050×1820	1350	1600

## 苏州梵洲科技有限公司

SUZHOU FANZHOU TECHNOLOGY CO.,LTD

江苏省常熟市阳光大道8号

No.8 Yangguang Road,Changshu City, Jiangsu, China

电话 T +86-15250337092

传真 F +86-15250337092

邮箱 E Juanschuan@gmail.com

Website: www.fanzhoultd.com

Whatsapp: +86-15250337092



Website

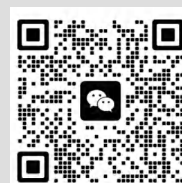

Wechat



Whatsapp